



# Physical interface guide

for Cisco TelePresence SX80

Thank you for choosing Cisco!

Your Cisco product has been designed to give you many years of safe, reliable operation.

Our main objective with this guide is to address your goals and needs. Please let us know how well we succeeded!

May we recommend that you visit the Cisco web site regularly for updated versions of this guide.

The user documentation can be found on  
▶ <https://www.cisco.com/go/telepresence/docs>

## How to use this guide

The top menu bar and the entries in the Table of contents are all hyperlinks. You can click on them to go to the topic.

## Table of contents

<b>Introduction</b> .....	<b>3</b>
User documentation .....	4
<b>Connecting to the codec</b> .....	<b>5</b>
Connect to LAN, microphones, loudspeakers, Touch 10, screens and power .....	6
Connect a PC (optional).....	7
About cameras.....	8
Connecting Cisco TelePresence SpeakerTrack 60 .....	9
Connecting Cisco TelePresence Precision 60 .....	10
Connecting Cisco TelePresence Precision 40 / PrecisionHD 1080p 4xS2 .....	11
Connecting Cisco Quad Camera.....	12
<b>The physical interface</b> .....	<b>13</b>
The front panel.....	14
The rear panel—overview.....	15
<b>Socket details</b> .....	<b>16</b>
Audio details .....	17
GPIO details .....	18
<b>Cisco contacts</b> .....	<b>19</b>



## Chapter 1

# Introduction

This document describes the physical interface of the following codec:

- Cisco TelePresence SX80

## User documentation

The user documentation for the Cisco TelePresence systems running the TC or CE software includes several guides suitable for various user groups.

- **Installation guide:**  
How to install the product
- **Getting started guide:**  
Initial configurations required to get the system up and running
- **Administrator guide:**  
Information required to administer your product
- **Quick reference guide:**  
How to use the product
- **User guide:**  
How to use the product
- **API reference guide:**  
How to use the Application Programmer Interface (API), and reference guide for the command line commands
- **Video conferencing room primer:**  
General guidelines for room design and best practice
- **Video conference room acoustics guidelines:**  
Things to do to improve the perceived audio quality
- **Software release notes**
- **Regulatory compliance and safety information**

## Downloading the user documentation

We recommend you to visit the Cisco web site regularly for updated versions of the user documentation. Go to:

► <https://www.cisco.com/go/sx-docs>



## Chapter 2

# Connecting to the codec

## Connect to LAN, microphones, loudspeakers, Touch 10, screens and power



Make sure all units are switched off when connecting or disconnecting cables.

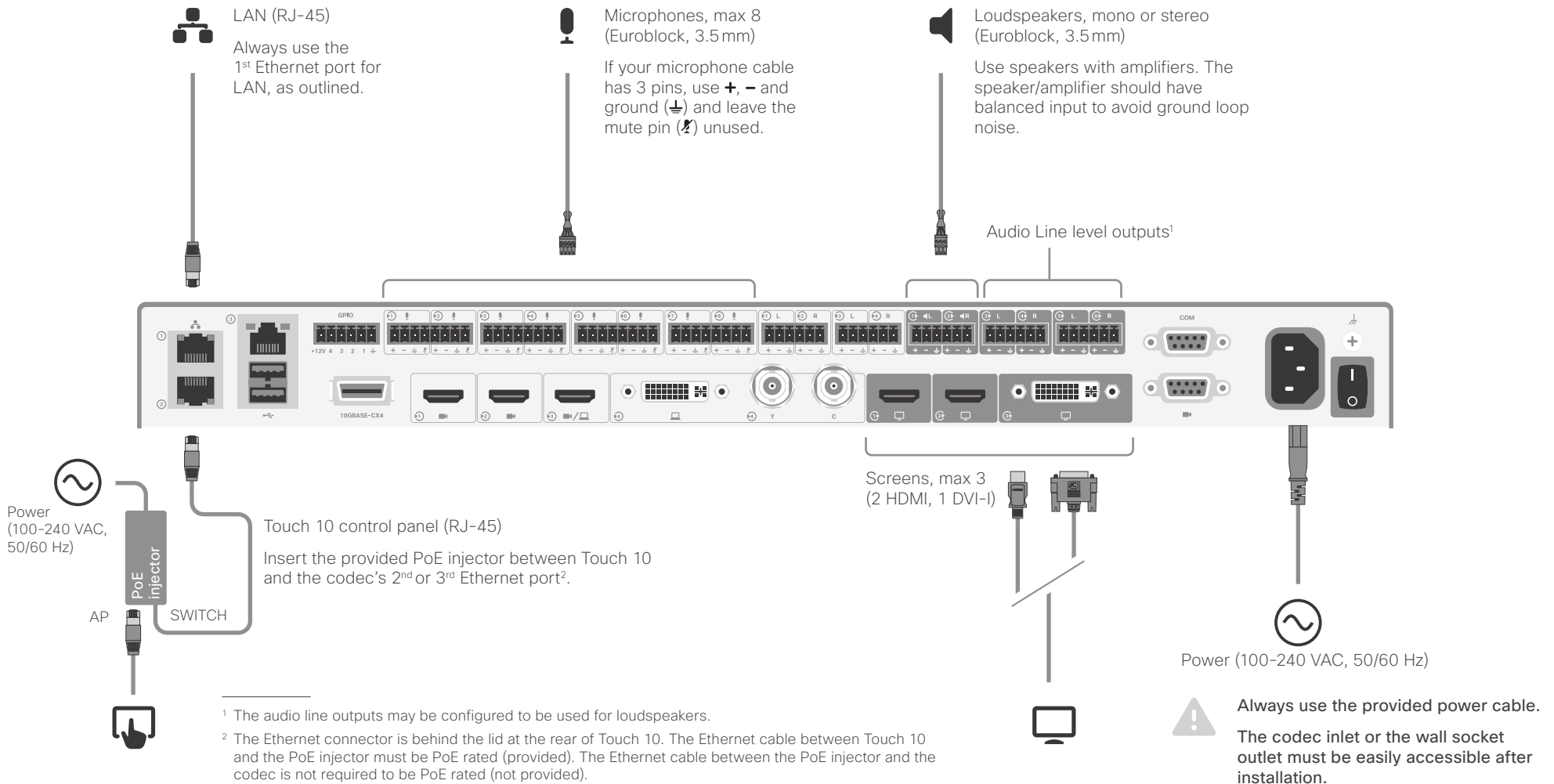

## Connect a PC (optional)

A PC can be connected to the codec to enable sharing of content locally or with conference participants.

Cisco offers a PC presentation cable that connects the codec's *DVI-I* input and *Audio line in* port (Euroblock), to the PC's *VGA* and *mini-jack* connectors; and a multihead cable that connects the codec's *HDMI input* to the *HDMI*, *DisplayPort*, or *Mini DisplayPort* on the PC.

Alternatively, you can use a standard HDMI cable.

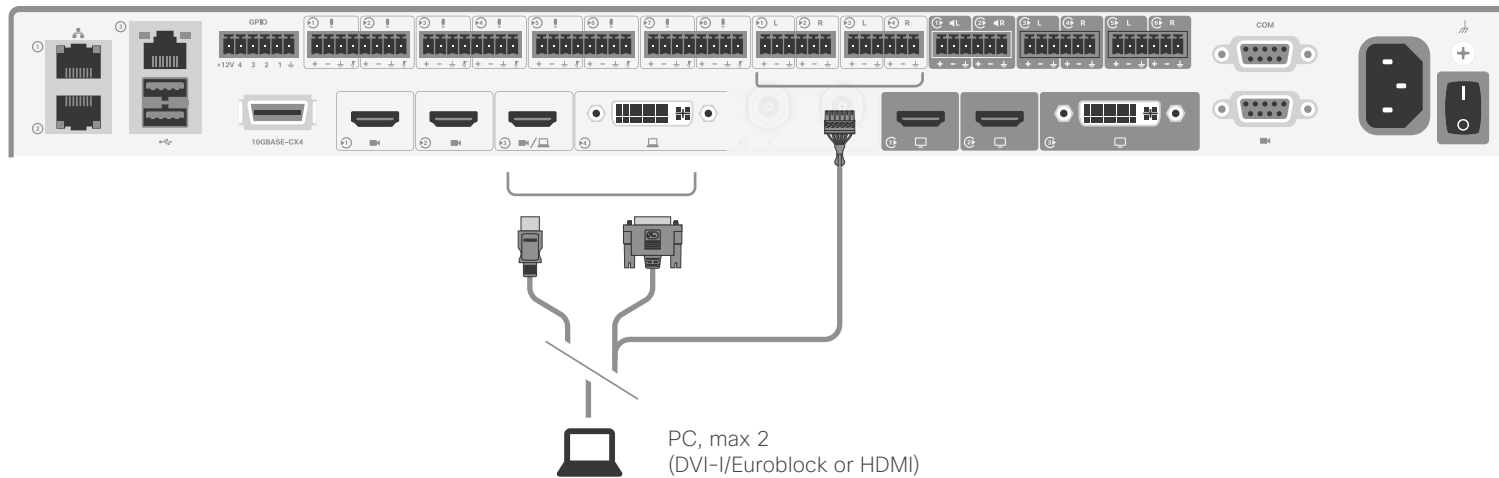

## About cameras

You can connect cameras, lap tops, and other input sources to the video inputs of the codec. The codec has the following inputs: three HDMI inputs, a DVI-I input, and an analog input. The DVI-I and analog inputs cannot be used simultaneously. If you need more inputs, you must add a video switcher.

Cisco provides the following cameras:

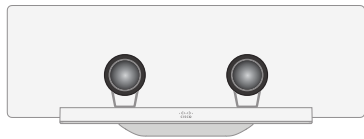

**Cisco TelePresence SpeakerTrack 60** is based on two Cisco TelePresence Precision 60 cameras and a microphone panel for advanced speaker tracking.

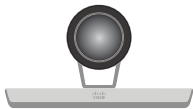

**Cisco TelePresence Precision 60** is a full HD camera with 1080p60 resolution, 20x total zoom, and wide angle view.



**Cisco TelePresence Precision 40 / Cisco TelePresence PrecisionHD 1080p 4xS2**<sup>1</sup> is a full HD camera with 1080p60 resolution and 4x optical zoom.



**Cisco Quad Camera** is a full HD camera with microphones for speaker tracking, auto-framing capabilities, and integrated loudspeakers.

You can use any combination of these cameras, as long as only one camera supports speaker tracking, and the maximum number of cameras does not exceed seven<sup>2</sup>.

<sup>1</sup> This camera is sold under two names. There is no difference.

<sup>2</sup> Note that Cisco TelePresence SpeakerTrack 60 counts as two cameras.

See how to connect the cameras on the following pages.

For more details about the Cisco cameras, refer to camera guides that are available at <https://www.cisco.com/go/telepresence/docs>



## Connecting Cisco TelePresence SpeakerTrack 60

Connect the two cameras in the SpeakerTrack 60 assembly to the codec's 1<sup>st</sup> and 2<sup>nd</sup> camera inputs (HDMI).

Also connect SpeakerTrack 60 to the codec's 2<sup>nd</sup> or 3<sup>rd</sup> Ethernet port, and to power.<sup>1</sup>

Refer to the installation guide that comes with SpeakerTrack 60 for further information about camera assembly and cabling.

**Tip!** Should you for any reason run out of Ethernet ports, just connect a switch to the codec's 2<sup>nd</sup> or 3<sup>rd</sup> Ethernet port. Never connect the switch to the 1<sup>st</sup> Ethernet port. This is reserved for LAN connection only.

### About the HDMI inputs

The codec automatically detects which video input each camera is connected to, as long as EDID information from the cameras is passed on to the codec.

This may not happen if you use an HDMI repeater. In such situations, when the codec does not receive EDID information from the cameras, you should connect the left camera (as seen from the front) to HDMI 1 and the right camera to HDMI 2.

You can use the following settings to override the default behavior:

[Cameras > SpeakerTrack > ConnectorDetection > Mode](#)

Set to **Manual** if you are going to decide yourself which connector each individual camera is connected to. Default value: **Auto**

[Cameras > SpeakerTrack > ConnectorDetection > CameraLeft](#)

The number of the video input that the left camera is connected to. Default value: **1**

[Cameras > SpeakerTrack > ConnectorDetection > CameraRight](#)

The number of the video input that the right camera is connected to. Default value: **2**

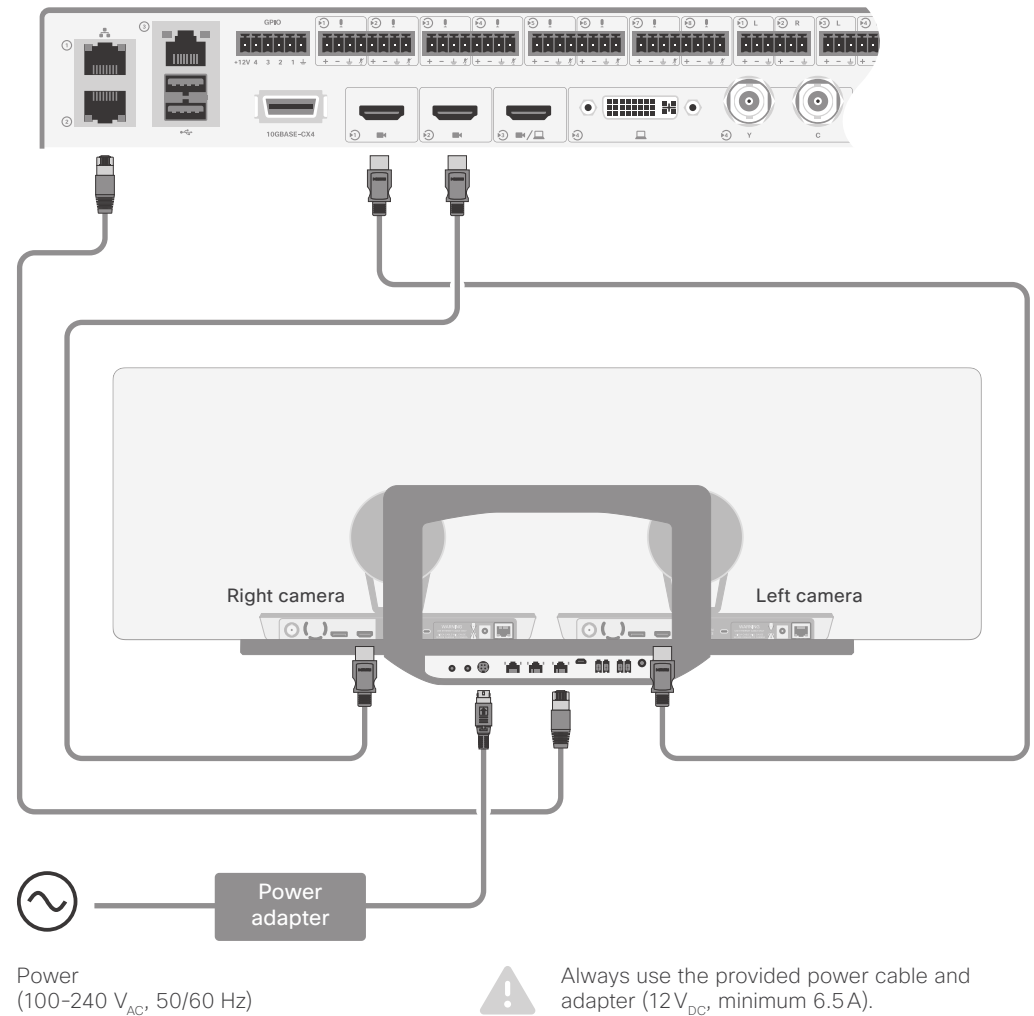

<sup>1</sup> Note that the camera surface is hot when the camera is in operation.

## Connecting Cisco TelePresence Precision 60

Connect the camera to one of the codec's camera inputs (HDMI).

Cisco recommends using the 1<sup>st</sup> camera input for the main camera.

Also connect the camera to the codec's 2<sup>nd</sup> or 3<sup>rd</sup> Ethernet port, and to power.<sup>1</sup>

**Tip!** Should you for any reason run out of Ethernet ports, just connect a switch to the codec's 2<sup>nd</sup> or 3<sup>rd</sup> Ethernet port. Never connect the switch to the 1<sup>st</sup> Ethernet port. This is reserved for LAN connection only.

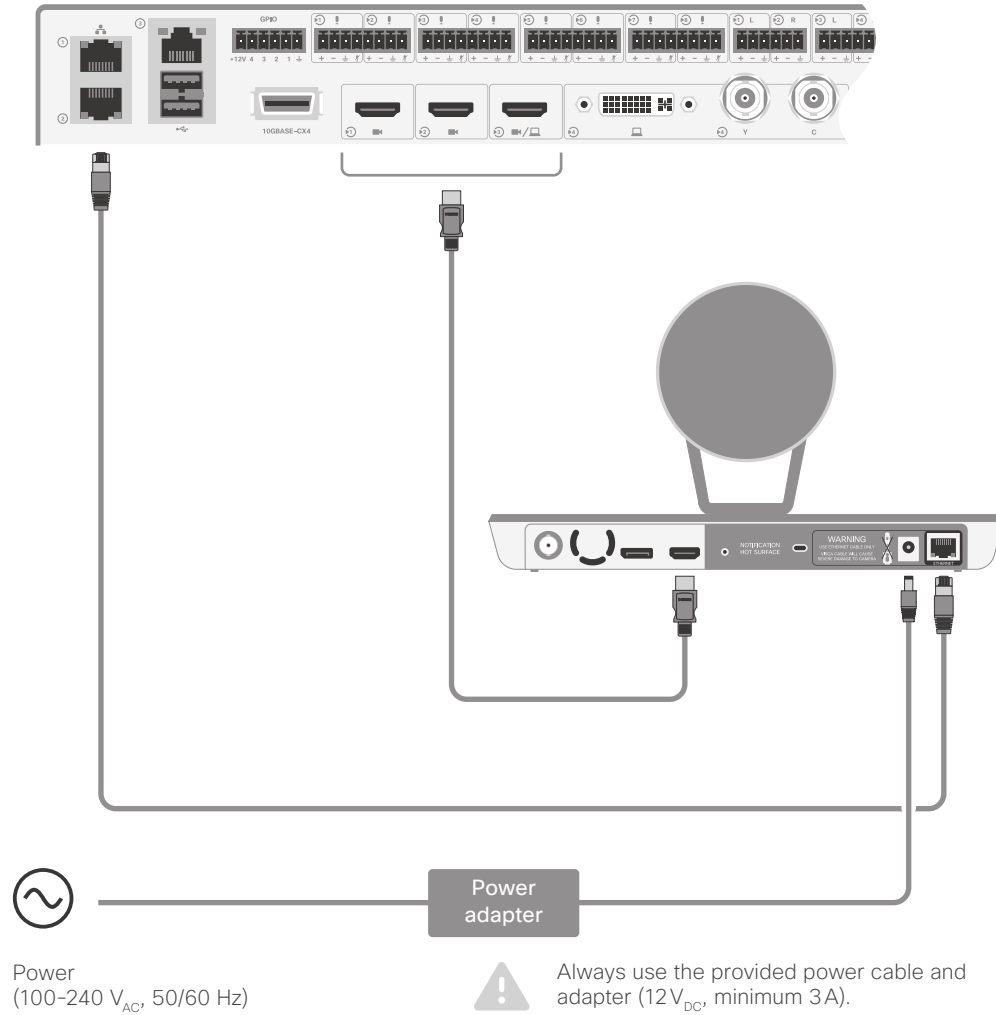

<sup>1</sup> Note that the camera surface is hot when the camera is in operation.

## Connecting Cisco TelePresence Precision 40 / PrecisionHD 1080p 4xS2

**Note:** This camera is sold under two names. There is no difference between Cisco TelePresence Precision 40 and Cisco TelePresence PrecisionHD 1080p 4xS2.

Connect the camera to one of the codec's camera inputs (HDMI).

Cisco recommends using the 1<sup>st</sup> camera input for the main camera.

Also connect the camera to the codec's dedicated camera control port (D-SUB 9), and to power.

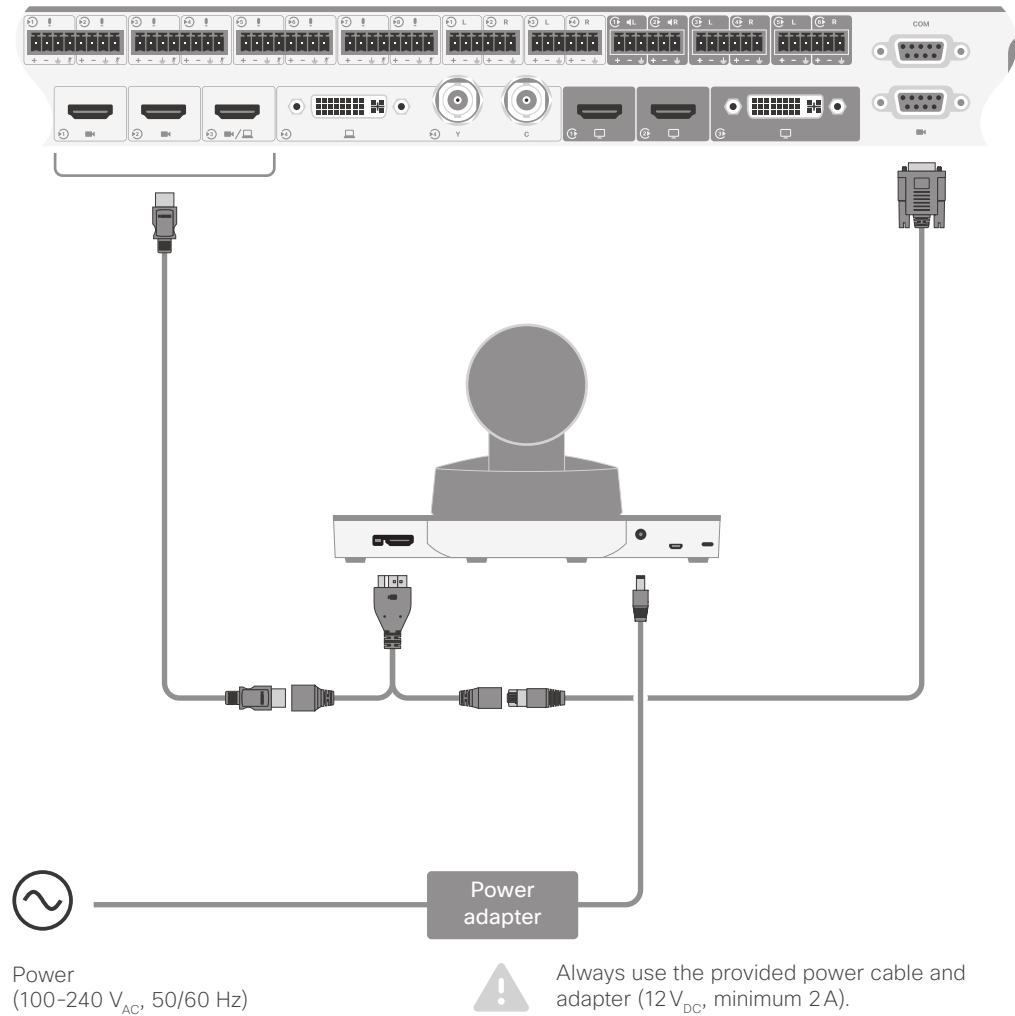

## Connecting Cisco Quad Camera

Connect the camera to one of the codec's camera inputs (HDMI). We recommend:

- Always use the codec's 1<sup>st</sup> camera input for the main camera.
- Use the camera's 1<sup>st</sup> HDMI output.

In order to play audio on the loudspeakers in the camera, connect the loudspeaker output of the codec (Euroblock) to the line input on the camera (mini-jack).

Also connect the camera to the codec's 2<sup>nd</sup> or 3<sup>rd</sup> Ethernet port, and to power.

**Tip!** Should you for any reason run out of Ethernet ports, just connect a switch to the codec's 2<sup>nd</sup> or 3<sup>rd</sup> Ethernet port. Never connect the switch to the 1<sup>st</sup> Ethernet port. This is reserved for LAN connection only.

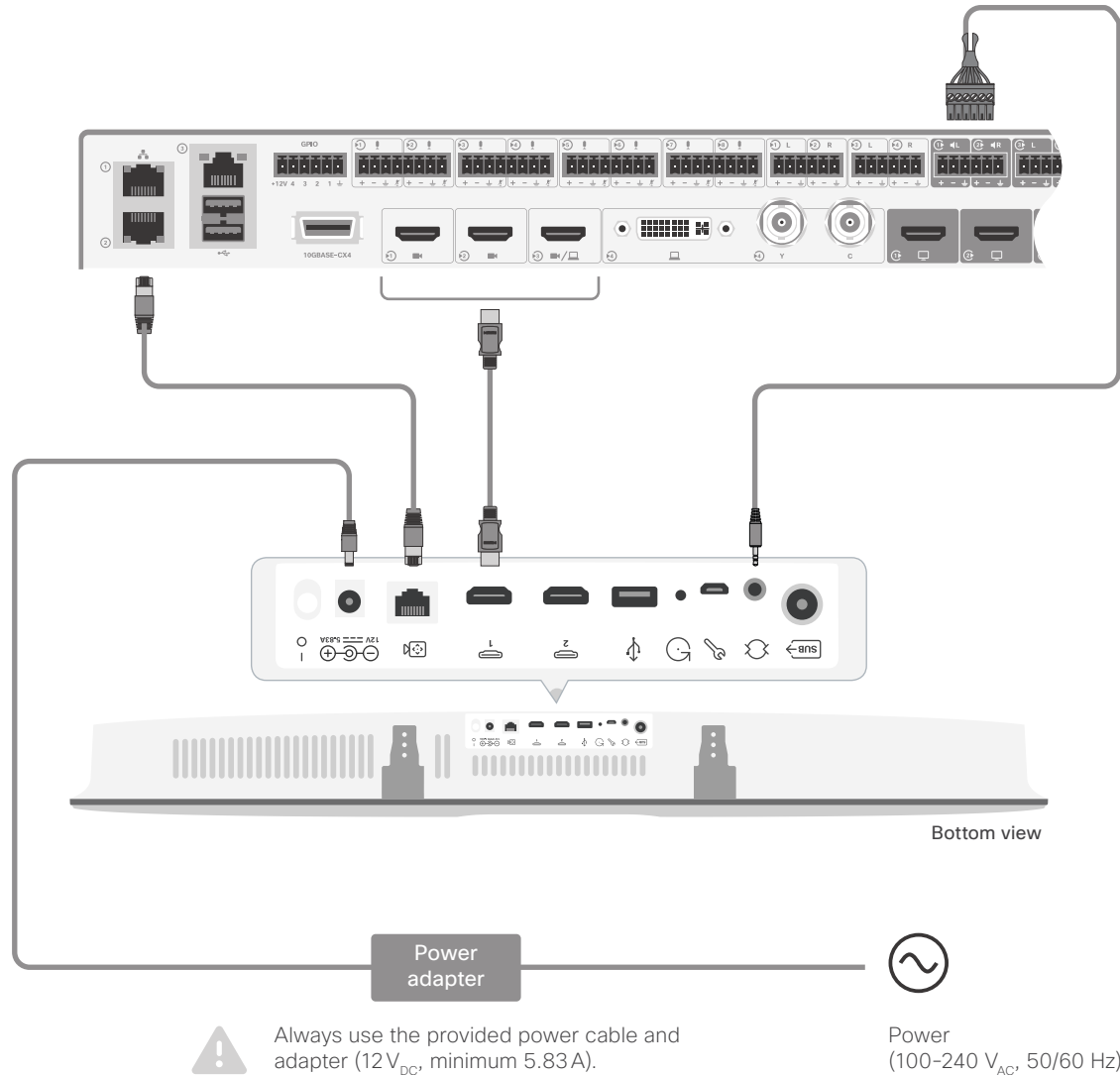

## Chapter 3

# The physical interface

## The front panel



### Shutdown button

The shutdown button on the front panel can be used to switch the codec on/off, provided the power switch on the codec's rear side is on.

- To switch off the codec, hold the button until the LEDs go out.
- To switch on the codec, hold the button until the LEDs flash. It may take a few minutes for the codec to start up. The system is ready for use when the Power LED lights steadily.

The shutdown button can also be used to factory reset the codec, more about this can be found in the Administrator guide for SX80.

### Front panel LEDs

#### *Power:*

- Blinks when the system is starting up.
- Steady light when the codec is ready for use.
- Pulsates when the codec is in standby.

#### *In Call:*

- Steady light when in call.

#### *IR:*

- Not in use.

#### *Alarm:*

- Lights steady when a serious error occurs.

## The rear panel—overview

**Tip!** Should you for any reason run out of Ethernet ports, just connect a switch to the codec's 2<sup>nd</sup> or 3<sup>rd</sup> Ethernet port.

Never connect the switch to the 1<sup>st</sup> Ethernet port. This is reserved for LAN connection only.

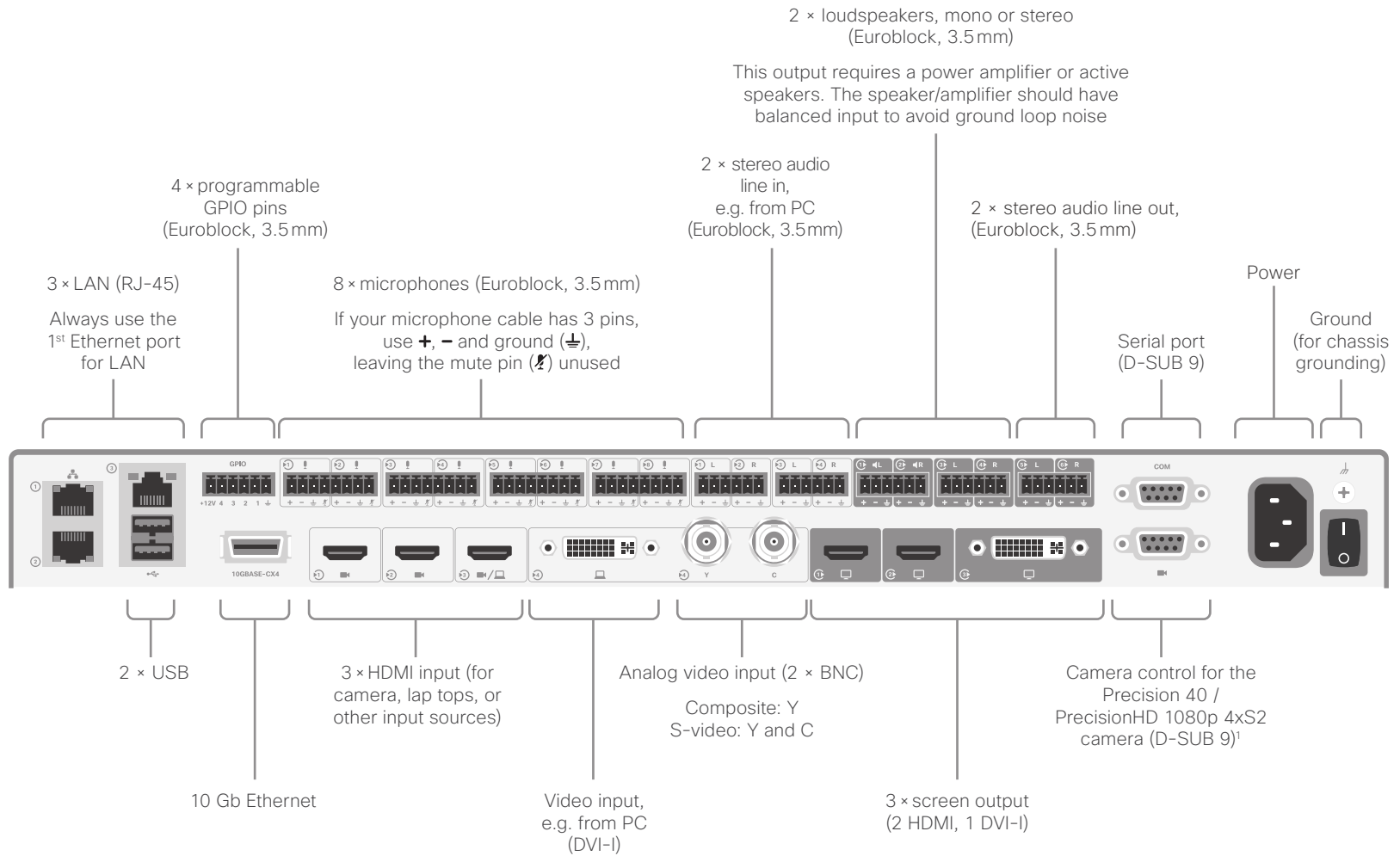

**Tip!** Should you for any reason run out of HDMI inputs, connect a video switcher to one of the inputs. The codec supports up to 7 cameras.

**Note:** The analog and DVI-I inputs are mutually excluding. You may only use either the DVI-I, the Composite, or the S-video at a time.

<sup>1</sup> There is no DC power output from the camera control port.



## Chapter 4

# Socket details



## Audio details

Audio Input/Output Levels			
	Microphone In	Line In	Line Out
Min. level	-48 dBu	-2 dBu	-2 dBu
Default level	-36 dBu	6 dBu	12 dBu
Max. level	22 dBu	22 dBu	22 dBu
No. of steps	70	24	24
0 dBu $\equiv$ 1 mW @ 600 $\Omega$ (0.775 V <sub>RMS</sub> )			

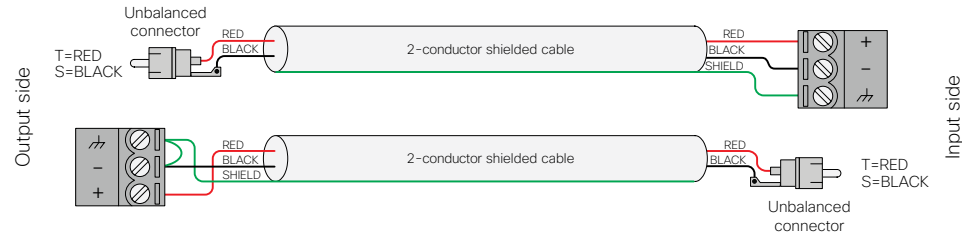

These illustrations show best practice when connecting the SX80 to unbalanced connectors.

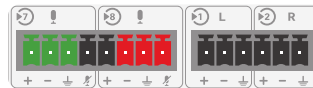

Connect as indicated by green when using Euroblocks with 3 connectors for microphones. Do not connect as indicated by red.

**Note:** The Microphone inputs are configured for the use of Euroblocks with up to 4 ports, while the Line In/Line Out are configured for the use of Euroblocks with 3 ports only.

If you use Euroblocks with 3 ports as microphone connectors make sure the Euroblock is inserted so that the Microphone Mute is not engaged, i.e. insert it in the leftmost position possible, marked using green in the lower left illustration.

## GPIO details

The device has one 6-pin Euroblock GPIO (General Purpose Input/Output) port with GND, +12V, and 4 GPIO pins.\*

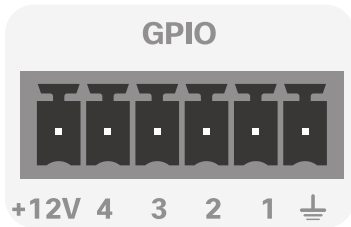

You can configure the mode for the four GPIO pins individually. A pin can be configured to trigger an action (input) or to report some status of the device (output). For example:

- Mute the microphones (input), or report whether the microphones are muted (output).
- Accept or disconnect a call (input), or report whether the device is in a call (output).

For more information about the API commands that are used to configure the GPIO pins, see the API guide for CE software. Go to: [▶ https://www.cisco.com/go/sx-docs](https://www.cisco.com/go/sx-docs)

### Operating principles

The +12V pin provides +12V<sub>DC</sub>, and it is capable of sourcing up to 500mA.

The GND pin is a common ground for all pins in the GPIO connector.

When used as input, a GPIO pin detects state as follows:

- Low state for voltages 0-1V<sub>DC</sub>
- High state for voltages 2-12V<sub>DC</sub>

When used as output, a GPIO pin is set as follows:

- Low state will drive a pin low, i.e. to GND
- High state will set a pin to open-drain with internal pull-up, i.e. it will set the pin to 12V unless an external connection drives it low

\* The numbering of the four GPIO pins are opposite compared to Codec Pro.

## Intellectual property rights

THE SPECIFICATIONS AND INFORMATION REGARDING THE PRODUCTS IN THIS MANUAL ARE SUBJECT TO CHANGE WITHOUT NOTICE. ALL STATEMENTS, INFORMATION, AND RECOMMENDATIONS IN THIS MANUAL ARE BELIEVED TO BE ACCURATE BUT ARE PRESENTED WITHOUT WARRANTY OF ANY KIND, EXPRESS OR IMPLIED. USERS MUST TAKE FULL RESPONSIBILITY FOR THEIR APPLICATION OF ANY PRODUCTS.

THE SOFTWARE LICENSE AND LIMITED WARRANTY FOR THE ACCOMPANYING PRODUCT ARE SET FORTH IN THE INFORMATION PACKET THAT SHIPPED WITH THE PRODUCT AND ARE INCORPORATED HEREIN BY THIS REFERENCE. IF YOU ARE UNABLE TO LOCATE THE SOFTWARE LICENSE OR LIMITED WARRANTY, CONTACT YOUR CISCO REPRESENTATIVE FOR A COPY.

The Cisco implementation of TCP header compression is an adaptation of a program developed by the University of California, Berkeley (UCB) as part of UCB's public domain version of the UNIX operating system. All rights reserved. Copyright © 1981, Regents of the University of California.

NOTWITHSTANDING ANY OTHER WARRANTY HEREIN, ALL DOCUMENT FILES AND SOFTWARE OF THESE SUPPLIERS ARE PROVIDED "AS IS" WITH ALL FAULTS. CISCO AND THE ABOVE-NAMED SUPPLIERS DISCLAIM ALL WARRANTIES, EXPRESSED OR IMPLIED, INCLUDING, WITHOUT LIMITATION, THOSE OF MERCHANTABILITY, FITNESS FOR A PARTICULAR PURPOSE AND NONINFRINGEMENT OR ARISING FROM A COURSE OF DEALING, USAGE, OR TRADE PRACTICE.

IN NO EVENT SHALL CISCO OR ITS SUPPLIERS BE LIABLE FOR ANY INDIRECT, SPECIAL, CONSEQUENTIAL, OR INCIDENTAL DAMAGES, INCLUDING, WITHOUT LIMITATION, LOST PROFITS OR LOSS OR DAMAGE TO DATA ARISING OUT OF THE USE OR INABILITY TO USE THIS MANUAL, EVEN IF CISCO OR ITS SUPPLIERS HAVE BEEN ADVISED OF THE POSSIBILITY OF SUCH DAMAGES.

Cisco and the Cisco Logo are trademarks of Cisco Systems, Inc. and/or its affiliates in the U.S. and other countries. A listing of Cisco's trademarks can be found at [www.cisco.com/go/trademarks](http://www.cisco.com/go/trademarks). Third party trademarks mentioned are the property of their respective owners. The use of the word partner does not imply a partnership relationship between Cisco and any other company. (1005R)

Any Internet Protocol (IP) addresses and phone numbers used in this document are not intended to be actual addresses and phone numbers. Any examples, command display output, network topology diagrams, and other figures included in the document are shown for illustrative purposes only. Any use of actual IP addresses or phone numbers in illustrative content is unintentional and coincidental.

TANDBERG is now a part of Cisco. TANDBERG® is a registered trademark belonging to Tandberg ASA.

## Cisco contacts

On our web site you will find an overview of the worldwide Cisco contacts.

Go to: ► <https://www.cisco.com/go/offices>

Corporate Headquarters  
Cisco Systems, Inc.  
170 West Tasman Dr.  
San Jose, CA 95134 USA